



**PERFORMANCE DATA SHEET
NEMA PREMIUM NR CAN NEMA 12 - 12**

Catalogue #: MQP-16S

HP	kW	Voltage	S.F. @ 60Hz	EFF.	P.F.	Frame	Design	L.R. Amps
3	2,24	230/460	1,25	86,5%	0,81	145T	B	32

60 Hz								Code	F.L. RPM
208	230	416	460	480	575	600			
/	8	/	4,00	/	/			K	3470

50 Hz								
FLA			S.F. @ 50Hz	Efficiency	Power Factor	Code	F.L. RPM	
190	380	415						
9,6	4,8		1,00	84,0%	0,850	H	2830	

Wgt. Lbs	PH	Duty	Insul. Class	Amb.	Elevation	Temp. Rise° C
60	3	Cont.	F	40°C	1000M (3,300 Ft)	55

% Efficiency		% Power Factor		Torque		Winding Resist. Ω	Safe Cold Start (Secs)
Full Load:	86,5%	Full Load:	0,81	Full Load Ft/Lbs	4,5		
3/4 Load:	86,0%	3/4 Load:	0,74	Locked Rotor %	200		
1/2 Load:	84,0%	1/2 Load:	0,61	Break Down %	300	3,8	20

Rotor Inertia Wk2 Lb-Ft2	Max Load Inertia Wk2 Lb-Ft2	Shaft Material	Frame Material	DE Bracket Type	ODE Bracket Type	Enclosure	NEMA Rating	Lead Wire Size
0,04	3,5	1045	Cast Iron	Cast Iron	Cast Iron	TEFC	IP55	14 AWG

Ball Bearings		Grease	Mount Type	Orientation	Paint	Sound Pressure @ 3FT	Sound Power
DE	ODE						
6205	6205	Sealed Bearings	Rigid	Horizontal	RAL6022	78	88

Inverter Duty, Motor meets MG1 parts 31.4.4.2	VFD SF	Constant Torque Range	Variable Torque Range	Constant HP RPM
	1,00	10:1	20:1	5400

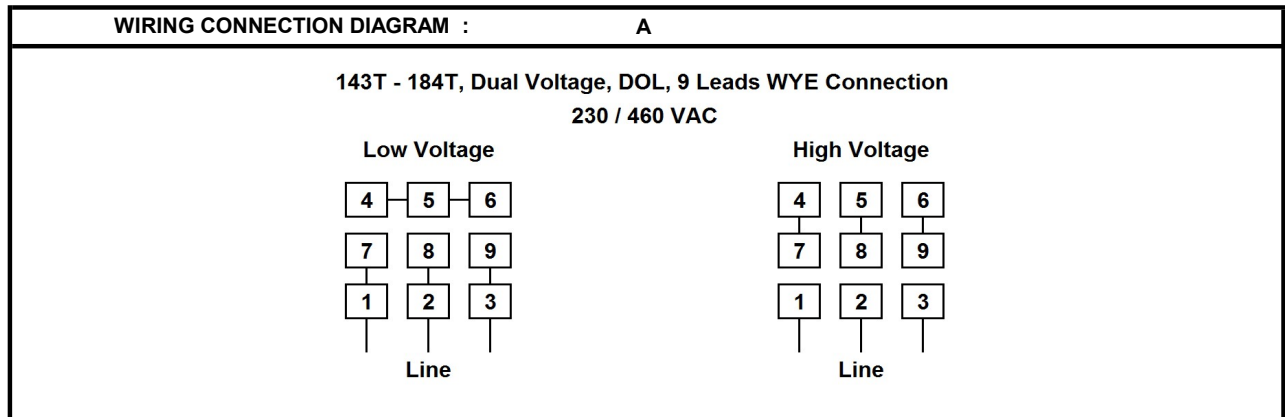

Date: 2023-12-13
 Customer: _____
 Contact: _____
 Submittee: J.C. Lavallée

Catalogue #: MQP-16S

NEMA PREMIUM NR CAN NEMA 12 - 12										
HP	VAC	RPM	Enclosure	Frame	Frequency	Design	Poles	LR Code Letter	Insulation Class	Temp. Rise °C
3	460	3470	TEFC	145T	60 Hz	B	2	K	F	55
	0Hz	6Hz	15Hz	30Hz	45Hz	60 Hz	75Hz	90Hz	105Hz	120Hz
Amps	4	4	4	4	4	4	4	4	4	4
RPM	0	347	867,5	1735	2602,5	3470	4337,5	5205	6072,5	6940
Torq ft.lb	3,63	3,63	4,54	4,54	4,54	4,54	3,63	3,03	2,59	2,27
Peak Tq ft.lb	5,68	11,35	11,35	11,35	11,35	11,35	9,08	7,57	6,49	5,68
HP	0	0,2	0,8	1,5	2,3	3,0	3,0	3,0	3,0	3,0
	Locked Rotor	Pull-Up	Breakdown	Rated Load	Idle	Duty	S. F.	Ambient	Elevation	dBA @ 1M
Speed (RPM)	0,0	1512	2880	3470	3600	Continuous	1,25	40°C	3,300 ft	78
Current (Amps)	32,0	27,2	19,0	4,0	2,0	VFD Rating: Meets MG1 parts 31.4.4.2				
Torque (ft.-lbs)	9,1	6,8	13,6	4,5	0,0	C.T.	10:1	V.T.	20:1	VFD SF 1.00

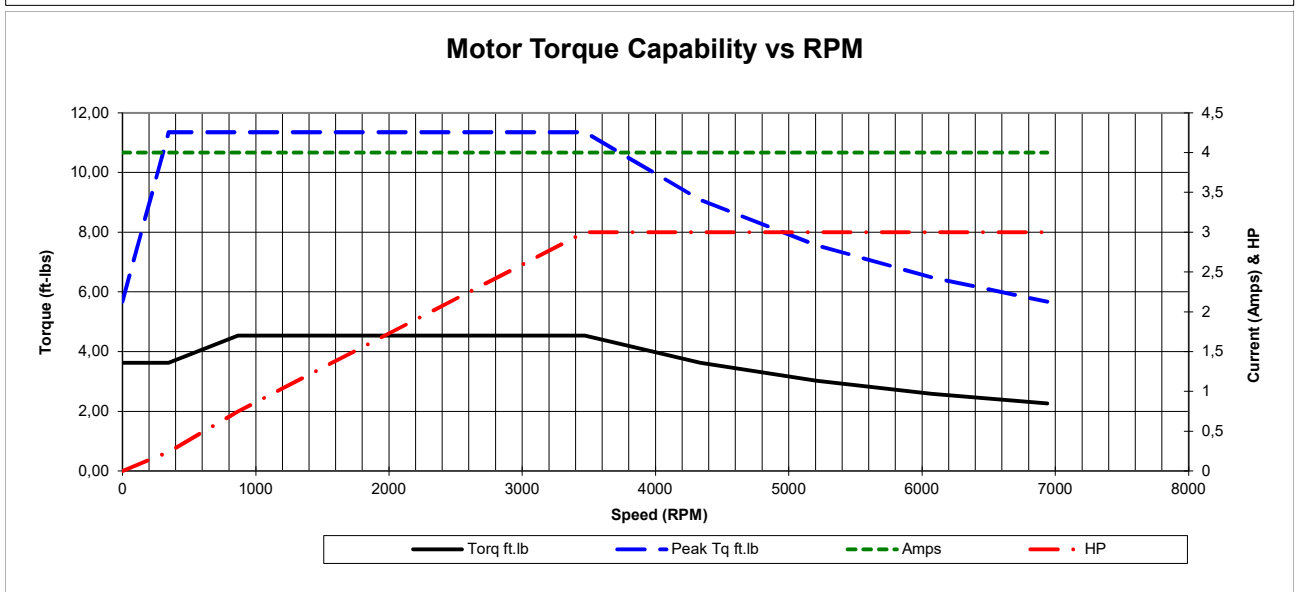
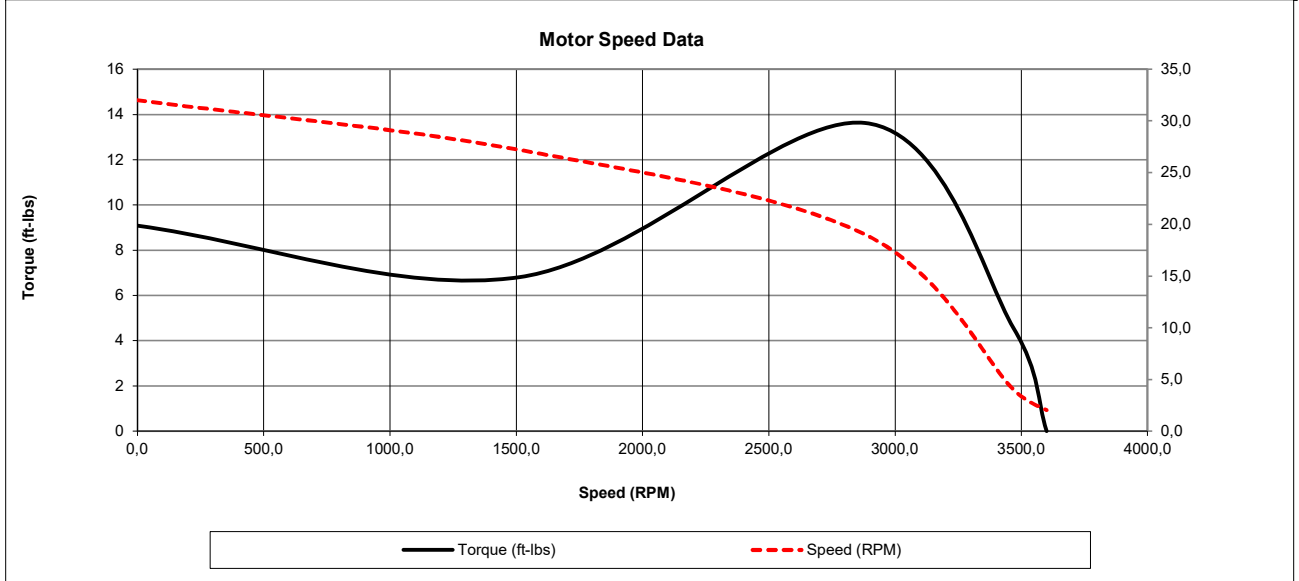



Date: 2023-12-13
 Customer: _____
 Contact: _____
 Submittee: J.C. Lavallée

Catalogue #: **MQP-16S**

NEMA PREMIUM NR CAN NEMA 12 - 12										
HP	VAC	RPM	Enclosure	Frame	Frequency	Design	Poles	LR Code Letter	Insulation Class	Temp. Rise °C
3	460	3470	TEFC	145T	60 Hz	B	2	K	F	55
Load %	0%	25%	50%	75%	100%	125%	150%			
Amps	2,04	2,34	2,68	3,28	4,00	4,90	5,81			
Torq ft/lbs	0	1,10	2,23	3,37	4,54	5,73	6,94			
RPM	0	3567,5	3535	3502,5	3470	3437,5	3405			
Eff	0	64,62	84,00	86,00	86,50	85,14	84,81			
PF	0	46,4	61	74	81	84,2319	85,5765			
	Locked Rotor	Pull-Up	Breakdown	Rated Load	Idle	Duty	S. F.	Ambient	Elevation	dBa @ 1M
Speed (RPM)	0	1512	2880	3470	3600	Continuous	1,25	40°C	3,300 ft	78
Current (Amps)	32	27,2	19,0	4	2,04	VFD Rating: Meets MG1 parts 31.4.4.2				
Torque (ft-lbs)	9,08	6,81	13,62	4,54	0,0	C.T.	10:1	V.T.	20:1	VFD SF 1.00

